



QUAD MAXI 4.1 - 4.2 - 4.3

Istruzioni per l'installazione - *Installation instructions*



Luce & Light
Pag. 1 - rev.04



IT



ATTENZIONE

Consigliamo di leggere con attenzione le seguenti istruzioni di conservarle.

IMPORTANTE:

- Prima di procedere all'installazione o alla manutenzione disinserire sempre l'energia elettrica.
- L'apparecchio deve essere installato da personale qualificato.
- Modifiche o manomissioni del prodotto, non autorizzate dall'azienda, annullano ogni condizione di garanzia.
- L'azienda **L&L Luce&Light** declina ogni responsabilità qualora l'installazione non avvenga secondo le norme vigenti.
- Le informazioni contenute nel presente documento possono essere modificate in qualsiasi momento senza preavviso e non comportano l'assunzione, nemmeno implicita, di alcuna obbligazione da parte della **L&L Luce&Light**.

COLLEGAMENTI ELETTRICI:

- Le lampade a LED funzionano con corrente costante.
- Per la scelta degli alimentatori fare attenzione alla **tensione** alla quale vanno alimentate le lampade e alla **potenza massima assorbita** riportata nei dati di targa del prodotto.
- **L'impianto va alimentato solo dopo che tutti i faretto sono collegati.**
- Lampade e alimentatori devono essere installati in scatole o luoghi con circolazione d'aria per permettere un naturale scambio di calore senza che vi sia un surriscaldamento dei dispositivi.

NOTE:

- In nessun caso l'apparecchio deve essere ricoperto da materiali termoisolanti o simili.



EN



WARNING!!!

Please read the following instructions carefully.

IMPORTANT:

- Although LED runs on a very low voltage, always cut off the power supply before installing the LED light or subjecting it to maintenance.
- Unauthorised alterations or tampering of the product will invalidate all the conditions of guarantee.
- This fixture must be installed by a qualified electrician.
- **L&L Luce&Light** is not responsible if its fixtures are not installed in according to local safety standards.
- Data contained in this document may be changed at any moment without prior notice and do not place **L&L Luce&Light** under any implicit or explicit obligation.

ELECTRICAL CONNECTIONS:

- LED lights run at constant current.
- As for the choice of the power supplies, please consider the tension through which they are fed and the max power consumption of LEDs you have to install.
- **The system must be feeded only if all the spots are connected.**
- The power supplies must be installed in aerated rooms, far from heat sources. A situation of overworking or a lack of air circulation will not permit a natural dissipation.

NOTES:

- Under no circumstance must this product be covered by thermal-insulating material or similar.



L&L Luce&Light srl
Via Trescalini, 5 - 36031 Dueville (VI) - Italy
Tel. +39 0444 360571 - Fax +39 0444 594304

www.lucelight.it - lucelight@lucelight.it

**RECESSED
INCASSI**

10/05/2023 12.30



QUAD MAXI 4.1 - 4.2 - 4.3

Istruzioni per l'installazione - *Installation instructions*



Luce & Light
Pag. 2 - rev.04



DE



ACHTUNG

Bitte lesen Sie sorgfältig die folgenden Anweisungen und bewahren Sie sie auf.

WICHTIG:

- Trennen Sie die Anlage immer vom Stromnetz bevor sie installiert oder gewartet wird.
- Die Anlage darf nur von Fachpersonal installiert werden.
- Bei unsachgemäßer oder der Gebrauchsanleitung zuwiderlaufender Benutzung erlischt die Garantie.
- L&L Luce&Light übernimmt keine Haftung bei nicht regelrechter Installation.
- Die in diesem Dokument enthaltenen Informationen können jederzeit und fristlos verändert werden und sind für **L&L Luce&Light** keine explizite oder implizite Verpflichtung.

ELEKTRISCHE VERBINDUNG:

- Die LED Lichter funktionieren mit konstantem Strom.
- Bei der Auswahl der Netzanschlußgeräte bitte beachten Sie den Strom, mit dem die LEDs versorgt werden, und die maximale Leistung der zu installierenden LEDs.
- Die Anlage darf nur dann versorgt werden, wenn alle Beleuchtungen angeschlossen sind.
- Lichter und Netzanschlußgeräte müssen in belüfteten Gehäusen oder Räumen installiert werden. Die erzeugte Wärme muss entweichen können, damit eine Überhitzung vermieden wird.
- Bei der Montage müssen alle auf nationaler Ebene gültigen Sicherheits- und Installationsvorschriften eingehalten werden
- Die Anlage darf niemals mit Dämmstoffen oder ähnlichen Materialien bedeckt werden.

BEMERKUNG:

Für den Anschluß der Kabel sollten Fäustlinge mit Harz oder agglomeriertes Klebeband verwendet werden um Eindringen des Wassers zu vermeiden.



4.1

FR



ATTENTION!!!

Lisez attentivement les instructions suivantes et conservez-les.

IMPORTANT:

- Avant d'effectuer les opérations d'installation ou de maintien, déconnectez toujours l'appareil du réseau électrique.
- L'appareil doit être installé par du personnel qualifié.
- Toute modification ou altération du produit, non autorisée par le fabricant, annule toutes les conditions de garantie.
- La société L&L Luce&Light décline toute responsabilité dérivant d'une installation non conforme aux normes en vigueur.
- Les informations contenues dans le présent document peuvent être modifiées dans n'importe quel moment sans préavis et ne comportent pas la prise en charge, explicite ou implicite, d'aucune obligation de la part de la société **L&L Luce&Light**.

CONNEXIONS ELECTRIQUES :

- Les lampes à DEL marchent à courant constant.
- Lorsque vous choisissez des alimentateurs, faites attention à la tension à laquelle il faut alimenter les lampes et à la puissance maximum absorbée par les DEL à installer.
- L'installation doit être alimentée seulement après avoir connecté tous les petits phares.
- Les lampes et les systèmes d'alimentation doivent être installés dans des boîtes ou des endroits où la circulation de l'air permet d'obtenir un échange de chaleur naturel, sans surchauffer les dispositifs.
- Pendant la mise en œuvre des opérations d'assemblage, observez les normes de prévention des accidents et d'installation en vigueur au niveau national.
- Ne recouvrez jamais l'appareil avec des matériaux thermo-isolants ou similaires.

NOTES:

Afin de mettre en œuvre la connexion des câbles, utilisez des chambres de raccordement avec de la résine ou une bande auto-agglomérant pour éviter toute infiltration d'eau.



4.2



4.3



L&L Luce&Light srl
Via Trescalini, 5 - 36031 Dueville (VI) - Italy
Tel. +39 0444 360571 - Fax +39 0444 594304

www.lucelight.it - lucelight@lucelight.it

**RECESSED
INCASSI**

10/05/2023 12.30



QUAD MAXI 4.1 - 4.2 - 4.3

Istruzioni per l'installazione - *Installation instructions*



Luce & Light

Pag. 3 - rev.04

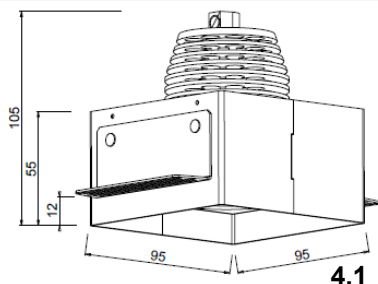

4.1

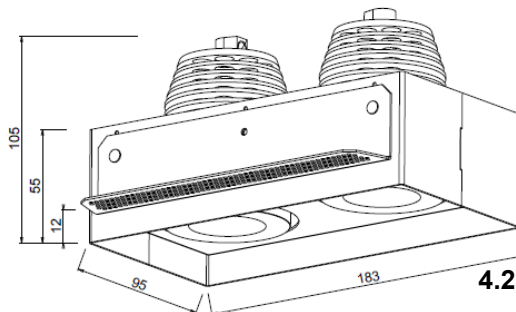

4.2

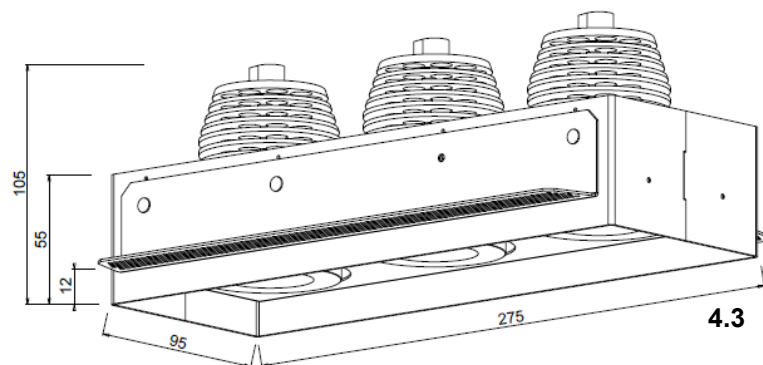

4.3

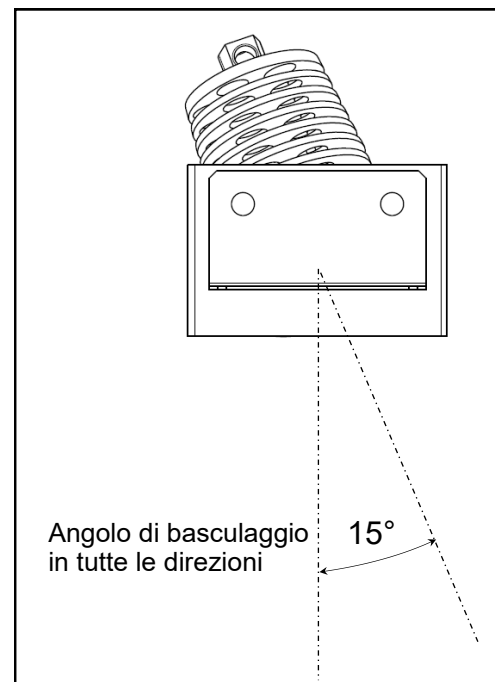

Angolo di basculaggio
in tutte le direzioni

15°

TECHNICAL DATA

POWER CONSUMPTION <i>POTENZA ASSORBITA</i>	max 14W (QM 4.1); max 26W (QM 4.2); max 40W (QM 4.3);
SUPPLY VOLTAGE <i>ALIMENTAZIONE</i>	230 Vac 50/60Hz
POWER SUPPLY UNIT <i>ALIMENTATORE</i>	Included and wired <i>Incluso e cablato</i>
POWER SUPPLY DIMENSIONS <i>DIMENSIONI ALIMENTATORE</i>	168x37x33 mm AC350040H1 110x67x22 mm (1-10V + PUSH) ADU- NITC 125x79x22 mm (1-10V + PUSH) AD050PUSHT1 125x79x22 mm (DALI + PUSH) AD050DALIT1
CONTROLLER <i>DIMMERAZIONE</i>	Dimming available with DALI, 1-10V, Push <i>Disponibile mediante controllo DALI, 1-10V o Push</i>
CONNECTION <i>COLLEGAMENTO</i>	230 Vac 50/60Hz
DIMENSIONS <i>DIMENSIONI</i>	107x107x110mm (QM 4.1); 107x197x110mm (QM 4.2); 107x287x110mm (QM 4.3);
WEIGHT <i>PESO</i>	0.50 kg (QM 4.1); 1.0 kg (QM 4.2); 1.50 kg (QM 4.3)
ACCESSORIES <i>ACCESSORI DISPONIBILI</i>	compulsory outer casing WC2401, WC2402, WC2403 (not included) <i>cassaforma obbligatoria WC2401, WC2402, WC2403 (non inclusa)</i>
RECESSED HOLE <i>FORO D'INCASSO</i>	95x95mm (QM 4.1); 95x185mm (QM 4.2); 95x275mm (QM 4.3)
OVERALL VOLUME <i>VOLUME TECNICO PER DISSIPAZIONE</i>	190x190x150mm (QM 4.1); 190x280x150mm (QM 4.2); 190x370x150mm (QM 4.3)
OPERATING TEMPERATURE <i>TEMPERATURA DI ESERCIZIO</i>	0°+ +45°
IP RATE <i>GRADO IP</i>	IP40; IP43 installed
SCREEN TEMPERATURE <i>TEMPERATURA SCHERMO</i>	Max 40°C (Ta 25°C)
INSULATION CLASS <i>CLASSE ISOLAMENTO</i>	Class II <i>Classe II</i>



L&L Luce&Light srl
Via Trescalini, 5 - 36031 Dueville (VI) - Italy
Tel. +39 0444 360571 - Fax +39 0444 594304

www.lucelight.it - lucelight@lucelight.it

**RECESSED
INCASSI**

10/05/2023 12.30



QUAD MAXI 4.1 - 4.2 - 4.3

Istruzioni per l'installazione - *Installation instructions*



Luce & Light
Pag. 4 - rev.04

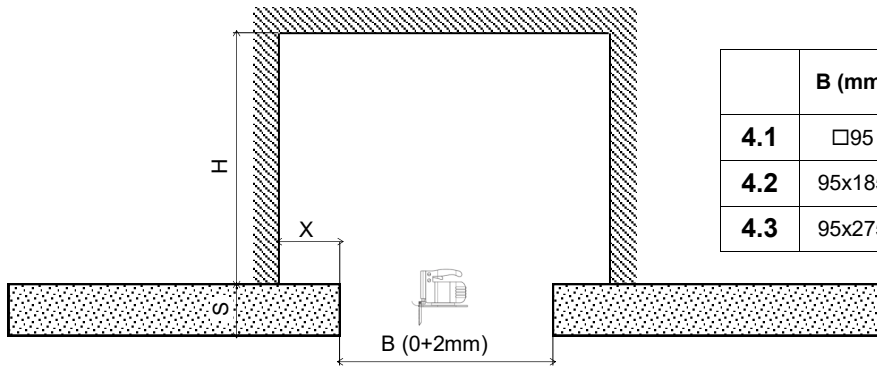

	B (mm)	X (mm)	S (mm)	H min (mm)
4.1	□95	50min	12	150
4.2	95x185	50min	12	150
4.3	95x275	50min	12	150

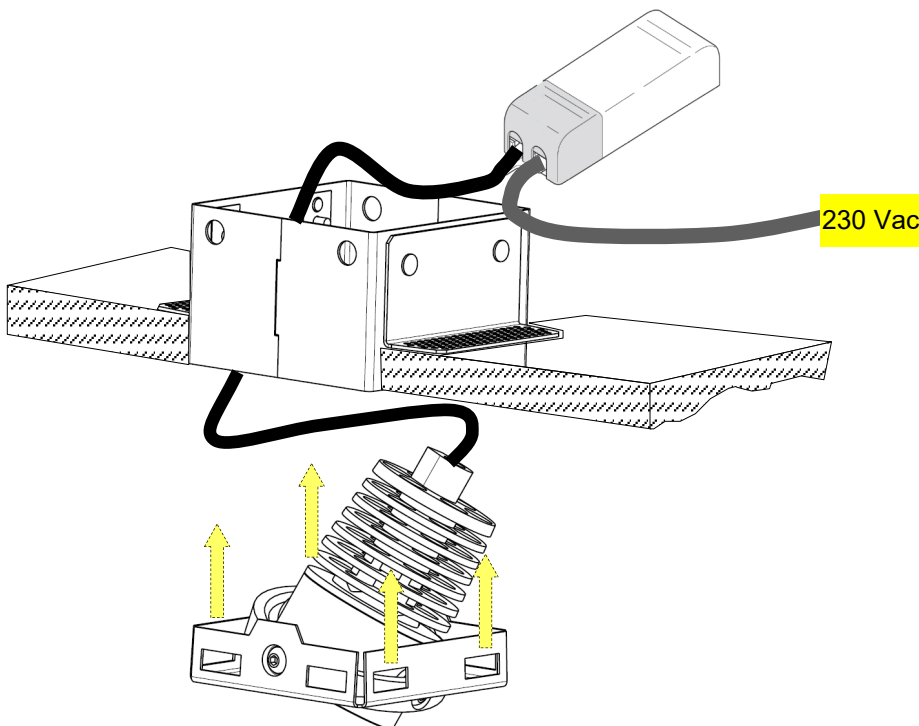
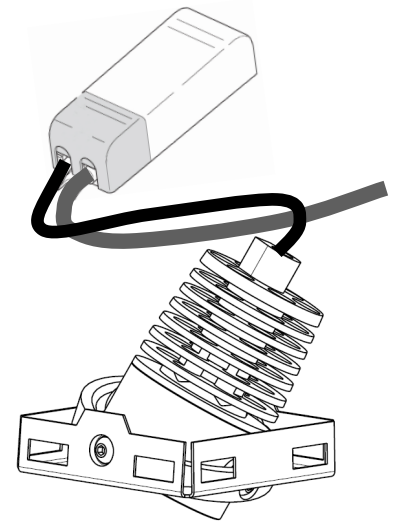
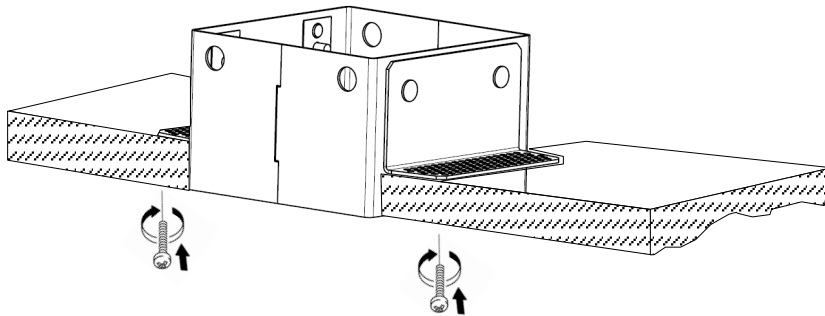



QUAD MAXI 4.1 - 4.2 - 4.3

Istruzioni per l'installazione - *Installation instructions*



Luce & Light
Pag. 5 - rev.04



Sgancio del faretto dalla cassaforma

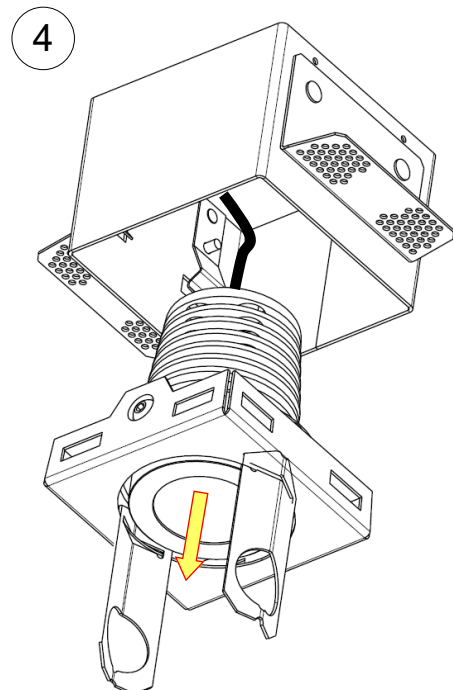
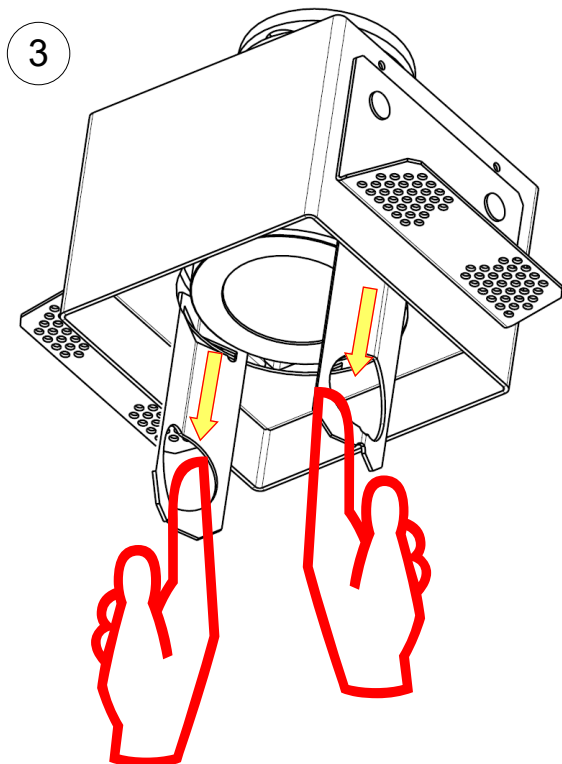
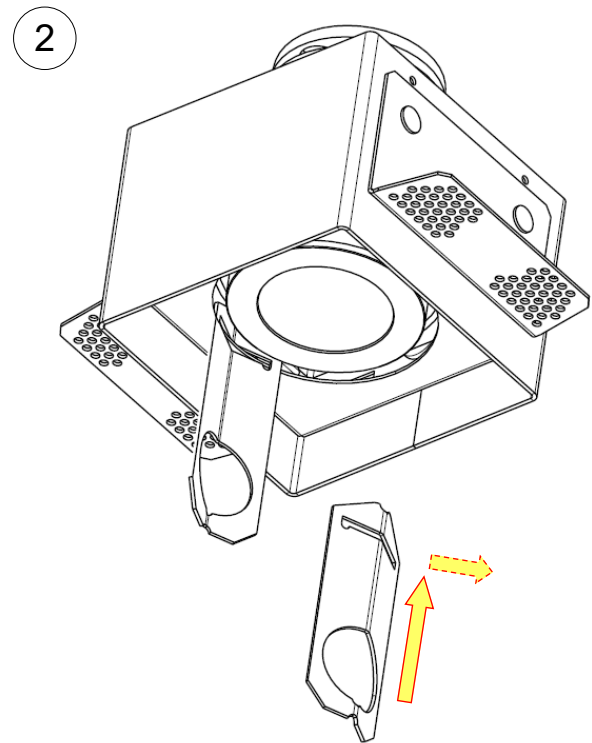
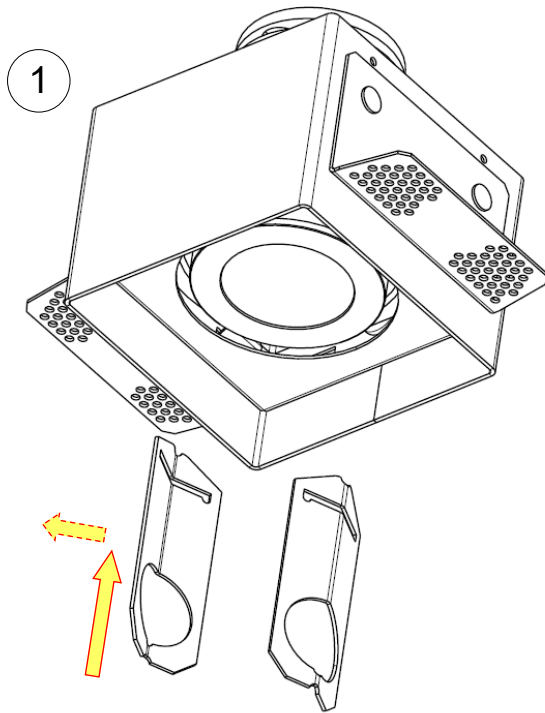

Dimmerazione del faretto tramite segnale 1-10V Con ADUNITC

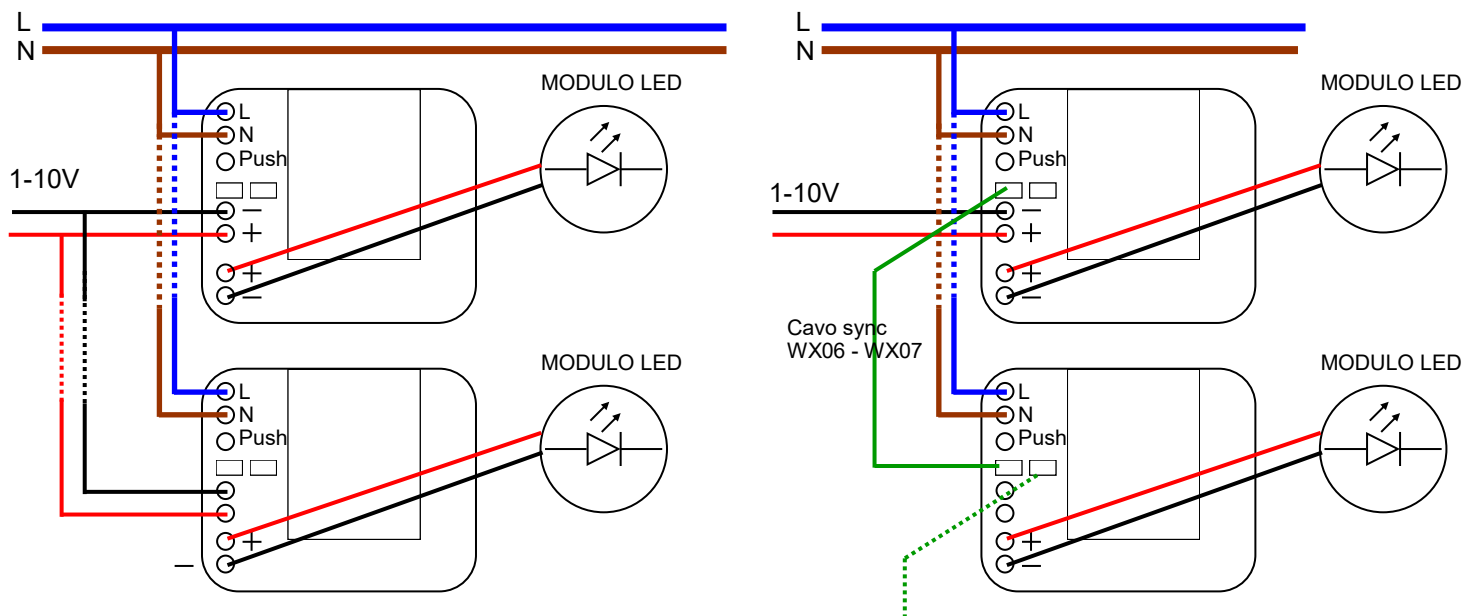

Dimmerazione del faretto tramite pulsante PUSH Con ADUNITC

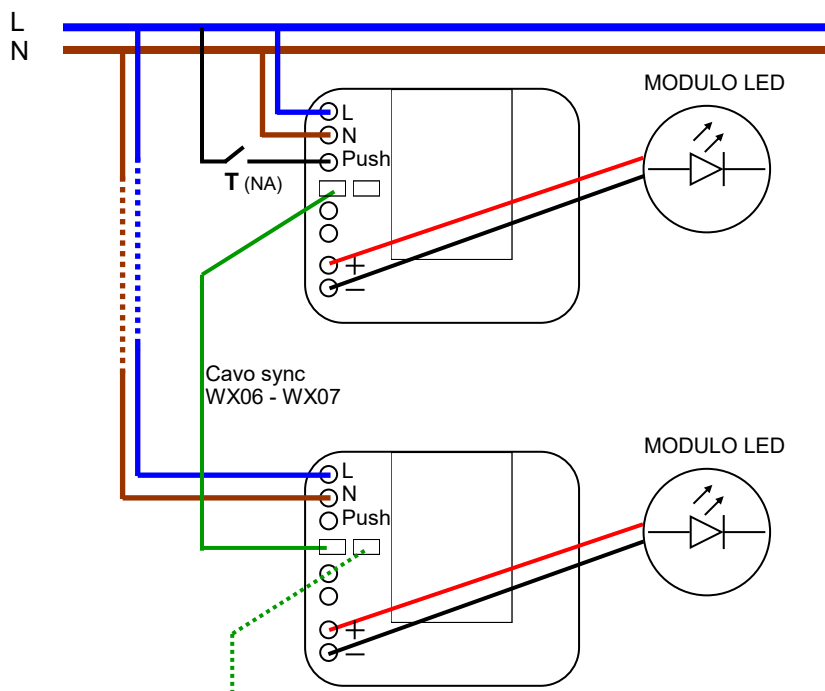

Per sincronizzare 2 o più alimentatori mettere in parallelo il pulsante del primo con gli altri. Possono essere sincronizzati un massimo di 4 alimentatori.

Procedura per sincronismo

Per sincronizzare più faretti agire con il pulsante come segue:

- • Pressione prolungata per 2 sec (si accendono tutti i faretti anche se a diversi livelli luminosi)
- • Rilascio del pulsante
- • Pressione veloce (spegnimento di tutti i faretti)
- • Pressione prolungata (si riaccendono e si sincronizzano)

Per sincronizzare 2 o più alimentatori utilizzare il cavetto di sincronizzazione apposito. Possono essere sincronizzati un massimo di 9 alimentatori.

Procedura per reset

Per resettare gli alimentatori e riportarli alle impostazioni iniziali cortocircuitare i morsetti 1-10V per 5-10 secondi...



Dimmerazione del faretto tramite segnale 1-10V Con AD020PUSHT1 - AD050PUSHT1

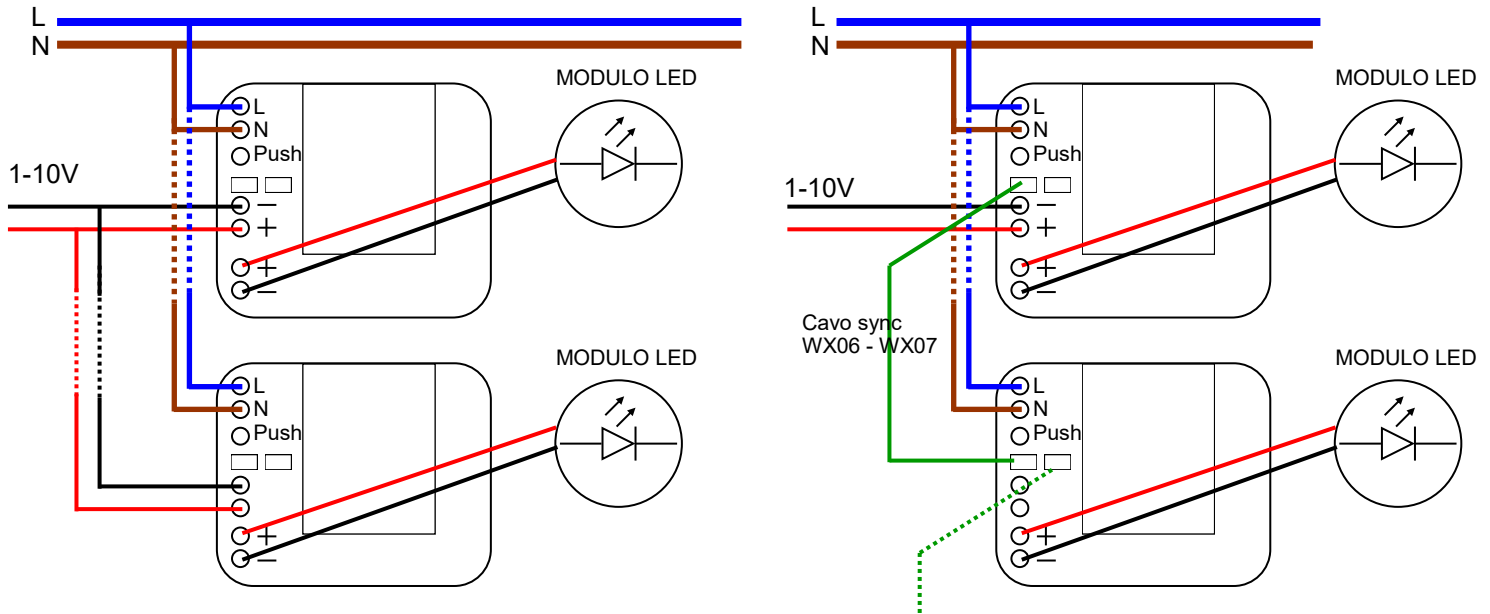

Dimmerazione del faretto tramite pulsante PUSH Con AD020PUSHT1 - AD050PUSHT1

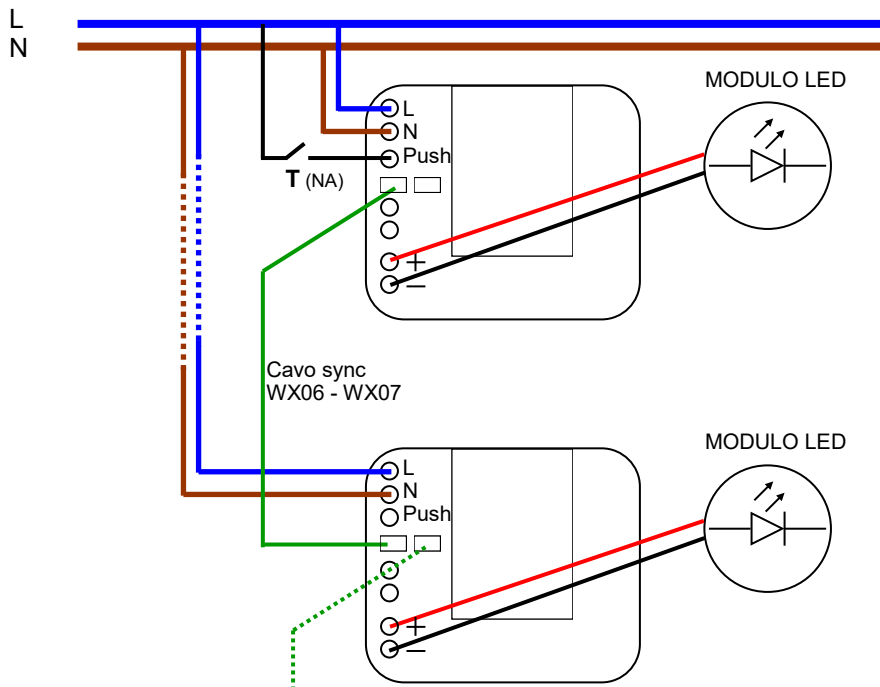

Per sincronizzare 2 o più alimentatori utilizzare il cavo di sincronizzazione apposito. Possono essere sincronizzati un massimo di 9 alimentatori.

Dimmerazione del faretto tramite segnale DALI con AD020DALIT1

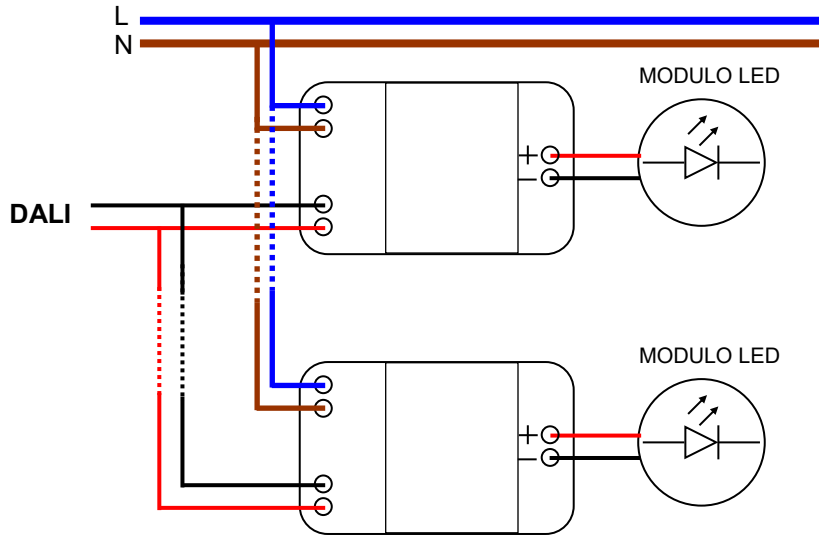

Dimmerazione del faretto tramite segnale DALI con AD050DALIT1

